

NSK

MEGATORQUE™ MOTOR SYSTEM User's Manual (EDC Driver Unit System) Optional Driver Unit with Analog Interface

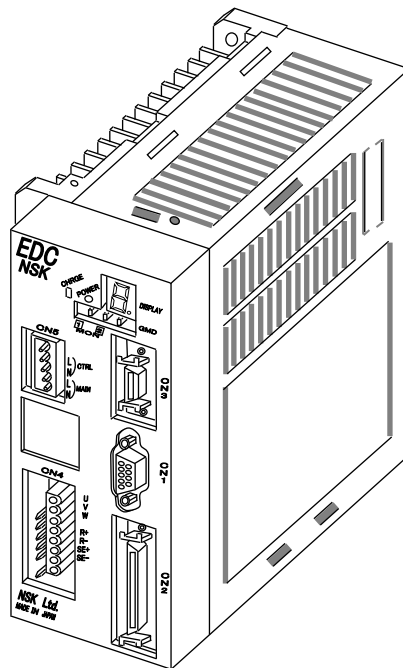

M-E099DC0C2-171

NSK Ltd.

Document Number: C20171-05

Limited Warranty

NSK Ltd. warrants its products to be free from defects in material and/or workmanship which NSK Ltd. is notified of in writing within, which comes first, one (1) year of shipment or 2400 total operation hours. NSK Ltd., at its option, and with transportation charges prepaid by the claimant, will repair or replace any product which has been proved to the satisfaction of NSK Ltd. to have a defect in material and/or workmanship.

This warranty is the sole and exclusive remedy available, and under no circumstances shall NSK Ltd. be liable for any consequential damages, loss of profits and/or personal injury as a result of claim arising under this limited warranty. NSK Ltd. makes no other warranty express or implied, and disclaims any warranties for fitness for a particular purpose or merchantability.

Copyright 2022 by NSK Ltd., Tokyo, Japan

All rights reserved.

No part of this publication may be reproduced in any form or by any means without permission in writing from NSK Ltd.

NSK Ltd. reserves the right to make changes to any products herein to improve reliability, function or design without prior notice and without any obligation.

NSK Ltd. does not assume any liability arising out of the application or use of any product described herein; neither does it convey any license under its present patent nor the rights of others.

Contents

1. Introduction -----	1-1
2. Specifications -----	2-1
2.1. System configuration -----	2-1
2.2. Reference Number and Coding -----	2-2
2.3. Dimension of EDC Drive Unit -----	2-2
2.4. Functional Specifications -----	2-4
2.5. Specifications related to resolution -----	2-4
2.6. Control I/O Connector Specification -----	2-5
2.6.1. Pin-Out (CN2) -----	2-5
2.6.2. CN2 Signal List -----	2-6
3. Analog Input Function -----	3-1
3.1. Interfacing -----	3-1
3.1.1. Analog Command Input -----	3-1
3.2. Velocity Control Mode -----	3-2
3.2.1. Velocity Control With RS-232C Command -----	3-2
3.2.2. Velocity Control With Analog Command -----	3-3
3.2.2.1. Offsetting Analog Velocity Command -----	3-4
3.3. Torque Control Mode -----	3-6
3.3.1. Torque Control With RS-232C Command -----	3-6
3.3.2. Torque Control With Analog Command -----	3-7
3.3.2.1. Offsetting Analog Torque Command -----	3-8
4. Glossary of Commands and Parameters -----	4-1
5. Conformity with the International Safety Regulations -----	5-1
5.1. Conformity with the EU Directives -----	5-1
5.2. Conformity with Electromagnetic Compatibility Directive -----	5-1
5.3. Conformity with Underwriters Laboratories Standards -----	5-4

(Blank Page)

1. Introduction

- This manual describes an option of the Megatorque Motor System that consists of the EDC Driver Unit with the Analog Interface. Please refer to the user's manual of the Megatorque Motor System (Document number: C20158) for other details.
- For your safety, please be sure to read the user's manual thoroughly before operating the Megatorque Motor System.

(Blank page)

2. Specifications

2.1. System Configuration

Figure 2-1: System configuration for analog command

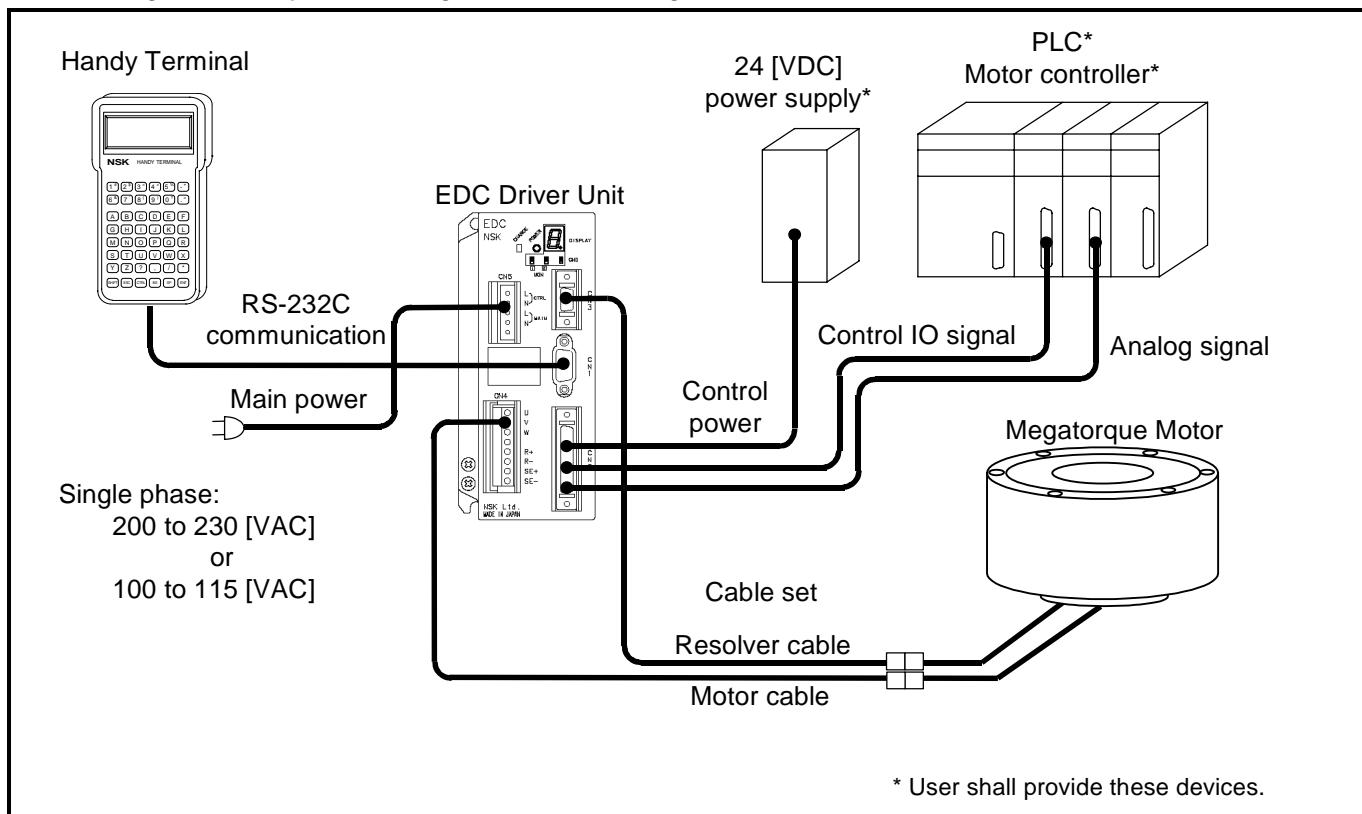

The optional parts listed below are not shipped with the Driver Unit.

Table 2-1 : Optional parts lists

Name	System Reference Number	Contents	
Connector	M-E014DCFS1-001	Connector for CN2	Connector :54306-5019(Molex) Shell :54331-0501(Molex)
	M-E014DCFS1-002	Connector for CN5	Connector :231-305/026-000(WAGO) Wiring lever :231-131(WAGO)
Driver Mounting Brackets	M-E050DCKA1-001	Qty 2, Includes screws (4-M3x8 countersunk Philips head)	
User's Manual	M-E099DC0C2-171	Megatorque Motor System User's Manual (EDC Driver Unit System)	
	M-E099DC0C2-158	Optional Driver Unit with Analog Interface Megatorque Motor System User's Manual (EDC Driver Unit System)	

2.2. Reference Number and Coding

Figure 2-2: Reference number coding of EDC Driver Unit

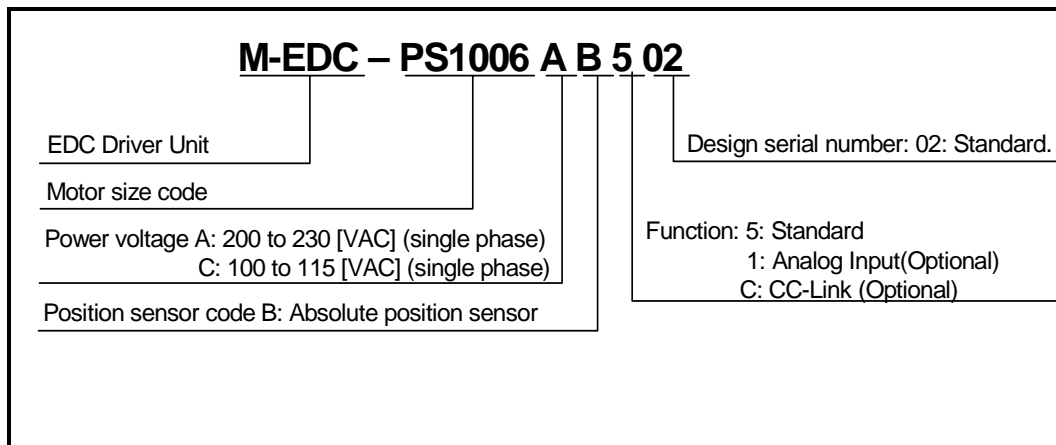

2.3. EDC Driver Unit

Figure 2-3: Dimension of Analog input type EDC Driver Unit (same as standard type)
(Motor type: PS1006, PS1012, PS1018, PS3015, PS3030, and PN2012)

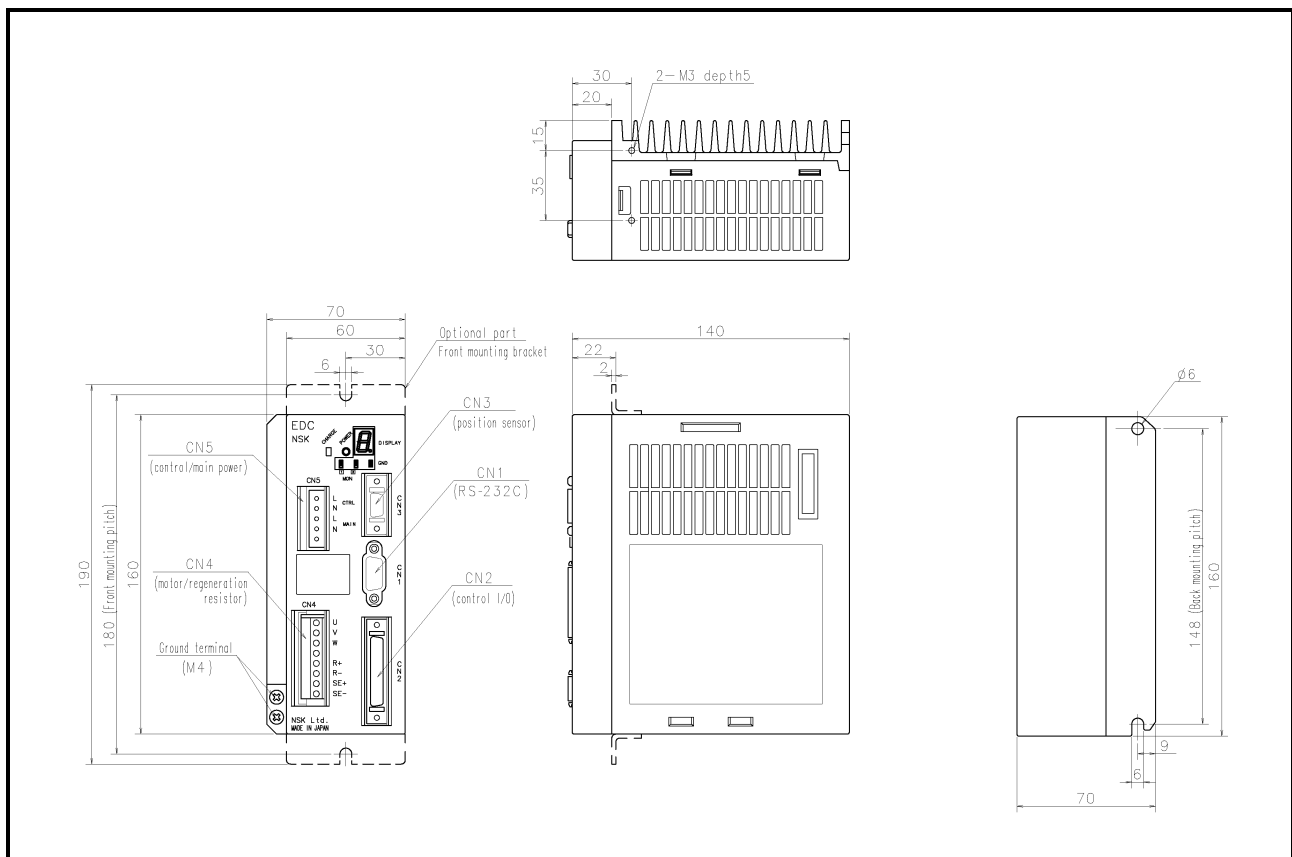
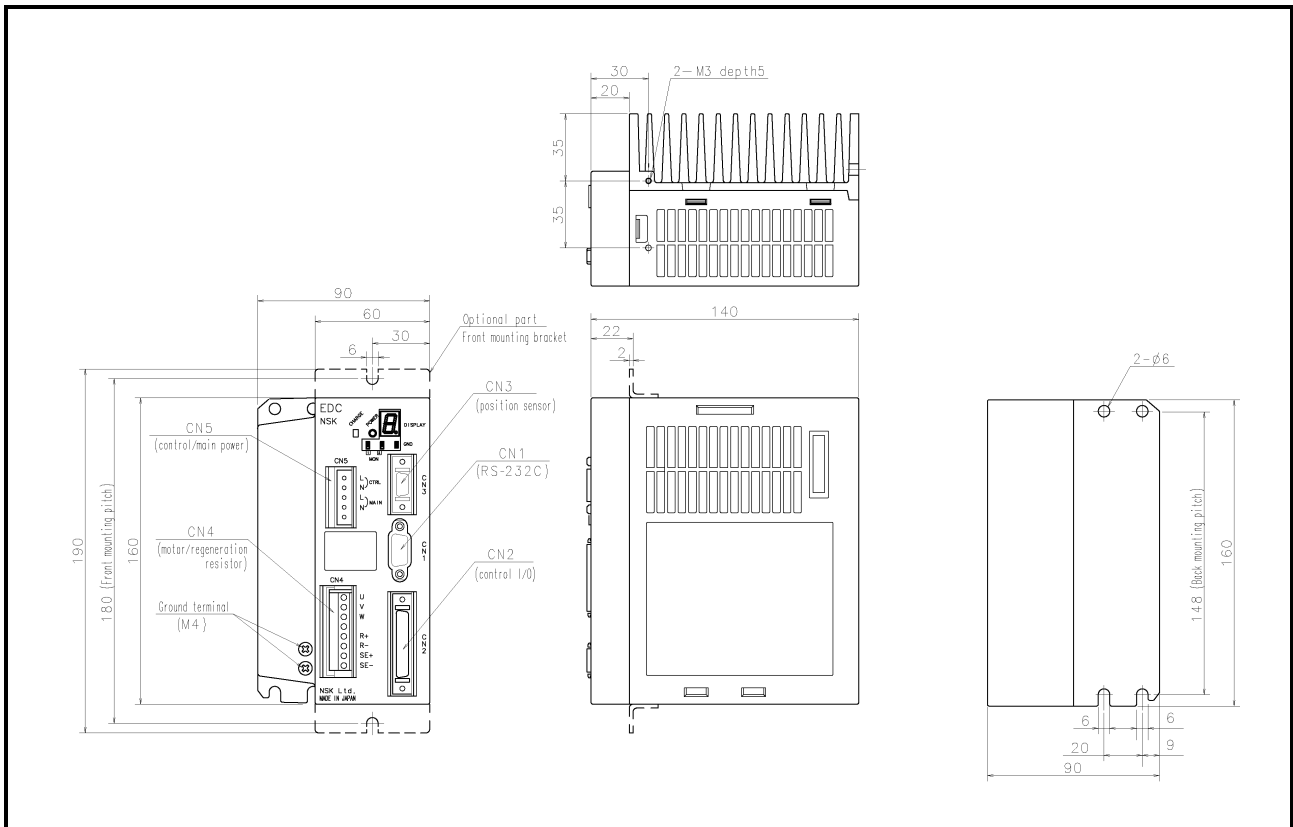

Figure 2-4: Dimension of Analog input type EDC Driver Unit (same as standard type)
 (Motor type: PS3060, PS3090, PN3045, PN4135, and PN4180)



2.4. Functional Specifications

Table 2-2: Functional Specification

Control mode	Velocity control	RS-232C serial communication , Analog command: ± 10 [VDC]
	Torque control	RS-232C serial communication , Analog command: ± 10 [VDC]
Input signals	Control Input	Emergency stop, Servo-on, Stop, Clear, Over travel limit, Integration OFF
Output signals	Position feedback	Refer to “2.5.Specifications related to resolution”
	Control Output	Driver Unit ready, Warning, Servo-state, \pm Travel limit detection, Under/Over velocity
Alarm functions		RAM error , ROM error , System error , Interface error , ADC error , Emergency stop , CPU error, Resolver Sensor error, Absolute position error, Motor cable disconnect error, Excessive velocity, Resolver excitation amplifier alarm, Commutation error , Over-heat, Main AC line over voltage, Excess current, Control AC line under voltage, Power module alarm , Software thermal error, Main AC line under-voltage, Over travel limit
Monitoring functions		Analog monitor $\times 2$ ch (Motor velocity, Motor velocity command, Motor velocity error, Torque command, Current command, Thermal load) RS-232C communications monitor (Position data, Alarm messages , Servo parameter, etc)
Communications		RS-232C serial communications (synchronous 9,600[bps])
Data back-up		EEPROM (The parameter can be rewritten 100,000 times)

2.5. Specification related to resolution

Table 2-3: resolution specification

Item		Specifications
Resolver Resolution		2,621,440[counts/revolution] ¹
Resolver Accuracy		90[arc-sec] compatible ¹ (when environmental temperature of 25 ± 5 [°C])
Position feed back signal output format		A/ B/ Z Line driver
Resolution of Position feedback signal	Phase A , \bar{A} Phase B , \bar{B}	20,480[pulses/revolution](default setting) (Quadrupled:81920) Up to 1,310,720[pulses/revolution] can be set ² (Quadrupled:5242880) (Maximum frequency remains 781 [k Hz])
	Phase Z , \bar{Z}	80[pulses/revolution]

¹Due to the speed limit of feedback signal and the resolution of analog command, performance such as high speed and high precision which are expected by using standard type EDC Driver Unit or CC-Link Type EDC Driver Unit may not exhibited by external controller.

²As the maximum frequency is 781 [kHz], the setting of the resolution limits the maximum velocity. The maximum velocity [s^{-1}] = 781[kHz] / phase A, and B resolution.

2.6. Control I/O Connector Specifications

Table 2-4: Mating connector

Connector	Manufacturer and model
Driver Unit's connector	Molex 52986 - 5071
Mating connector (user's device side)	Molex 54306 - 5019
Mating connector shell (user's device side)	Molex 54331 - 0501

Use shielded cable for wiring of the CN2 connector and be sure to use twisted cables for the position feed back signals. Wiring length shall be short as possible. (2[m] maximum)

2.6.1. Pin-Out (CN2)

The pin-out arrangement below is for the shipping set. The function of each signal port may be changed by the function setting of control Input/Output ports.

Figure 2-5: CN2 pin out (shipping set)

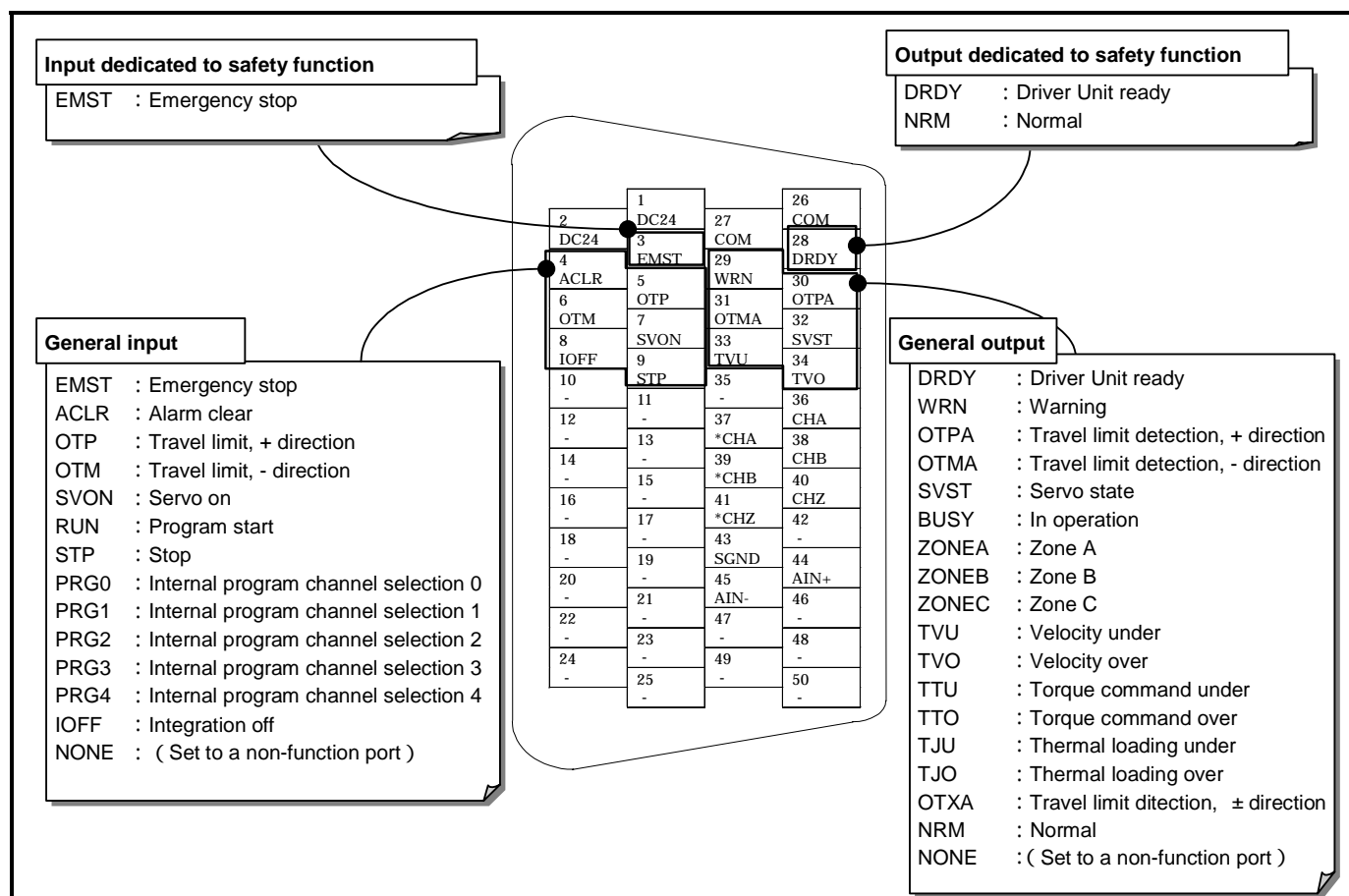

Pin number 3 and Pin number 28 are the dedicated ports to the safety function input and output respectively.

- You cannot change the function setting to the Pin number 3: EMST input [Emergency stop]. You may only set the logic of the connector and the stability timer to it.
- You can only change the function of the Pin number 28: DRDY output [Driver Unit ready] to the function NRM (normal) output. You cannot set the output logic and the stability timer to it.

2.6.2. CN2 Signal List

 **Caution** : Follow the specification documents for the specially ordered System when its settings of Inputs and Outputs are different from the standard.

 **Caution** : Never connect the idle pins that are instructed as “Do not connect.” Do not disconnect the idle pins at the master controller (PLC, etc) side after you have connected all pins of the CN2 connector.

Table 2-5: CN2 signal name and function (Shipping set)

Input Output	Pin No	Port code	Signal code	Contact logic	Signal name	Function
Input	1	-	DC24	-	24 [VDC] external power supply	External power supply for input signal
	2	-	DC24	-	24 [VDC] external power supply	External power supply for input signal
	3	PI0	EMST	Normally closed	Emergency stop	Terminates positioning operation and the Motor stops by the dynamic break.
	4	PI1	ACLR	Normally open	Alarm clear	Clears warning.
	5	PI2	OTP	Normally closed	Over travel limit, + direction	If OTP goes active, the Motor servo is locked in the CW direction.
	6	PI3	OTM	Normally closed	Over travel limit, - direction	If OTM goes active, the Motor servo is locked in the CCW direction.
	7	PI4	SVON	Normally open	Servo-on	If SVON goes active, the servo turns on and the System waits for a command to be entered.
	8	PI5	IOFF	Normally open	Integration OFF	Terminates velocity integration control.
	9	PI6	STP	Normally open	Stop	Stops positioning operation and execution of the program.
	10	-	-	-	(Do not connect)	-
	11	-	-	-	(Do not connect)	-
	12	-	-	-	(Do not connect)	-
	13	-	-	-	(Do not connect)	-
	14	-	-	-	(Do not connect)	-
	15	-	-	-	(Do not connect)	-
	16	-	-	-	(Do not connect)	-
	17	-	-	-	(Do not connect)	-
	18	-	-	-	(Do not connect)	-
	19	-	-	-	(Do not connect)	-
	20	-	-	-	(Do not connect)	-
	21	-	-	-	(Do not connect)	-
	22	-	-	-	(Do not connect)	-
	23	-	-	-	(Do not connect)	-
	24	-	-	-	(Do not connect)	-
	25	-	-	-	(Do not connect)	-

Table 2-5 (continued): CN2 signal name and function (Shipping set)

Input Output	Pin No.	Port code	Signal code	Contact logic	Signal name	Function
Output	26	–	COM	–	Output signal common	Common for output signal.
	27	–	COM	–	Output signal common	
	28	PO0	DRDY	Positive	Driver Unit ready	Reports that the Motor is ready to rotate. (Those pins are open when the Motor is not ready or an alarm occurs.)
	29	PO1	WRN	Negative	Warning	Warns abnormality in the System.
	30	PO2	OTPA	Negative	Over travel limit (+ direction) detected	Reports the output of over travel limit (software and hardware) in the plus direction.
	31	PO3	OTMA	Negative	Over travel limit (- direction) detected	Reports the output of over travel limit (software and hardware) in the minus direction.
	32	PO4	SVST	Positive	Servo state	Reports the state of servo.
	33	PO5	TVU	Positive	Velocity, under	Reports condition of velocity against the threshold value.
	34	PO6	TVO	Positive	Velocity, over	
	35	–	–	–	(Do not connect.)	–
	36	–	CHA	–	Position feedback signal ϕA	A pulse signal that reports the number of rotations of the Motor.
	37	–	*CHA	–	Position feedback signal ϕ^*A	
	38	–	CHB	–	Position feedback signal ϕB	Free setting of output resolution in $\phi A/\phi B$ phase is available.
	39	–	*CHB	–	Position feedback signal ϕ^*B	
	40	–	CHZ	–	Position feedback signal ϕZ	
	41	–	*CHZ	–	Position feedback signal ϕ^*Z	
	42	–	–	–	(Do not connect.)	–
	43	–	SGND	–	Signal ground	Ground for the position feedback signal.
	44	–	AIN+	–	Analog command (+)	$\pm 10[VDC]$ input for analog velocity or torque control.
	45	–	AIN-	–	Analog command (-)	
	46	–	–	–	(Do not connect.)	–
	47	–	–	–	(Do not connect.)	–
	48	–	–	–	(Do not connect.)	–
	49	–	–	–	(Do not connect.)	–
	50	–	–	–	(Do not connect.)	–

(Blank page)

3. Analog Input function

⚠ Caution : Constrain of motor speed

- Each motor type has its maximum speed. Check the maximum speed in the specification sheet.
- The parameter VL (Velocity limiter) depends on parameter FR (Feedback signal resolution).

⚠ Caution : Positioning control by external controller

- Due to the speed limit of feedback signal and the resolution of analog command, performance such as high speed and high precision which are expected by using standard type EDC Driver Unit or CC-Link Type EDC Driver Unit may not exhibited by external controller.

⚠ Caution : Analog Command Offset (AF)

- Offset adjustment of the Driver Unit has been made at the shipping. With the parameter AF, reset the offset along the master controller.

3.1. Interfacing

3.1.1. Analog Command Input

Applied input: AIN +, AIN –

Table 3-1: Specifications of analog command input

Item	Specification
Max. input voltage	± 10 [VDC]
Input impedance	20 [k Ω]
Maxi. input current	0.5 [mA]
ADC resolution	12 [bits]
Effective resolution	Typical 10 [bits]
Offset error	± 13 [%] of maximum input voltage

Figure 3-1: Analog input specification

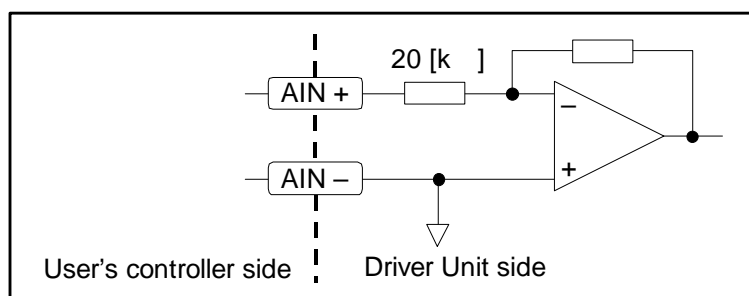

3.2. Velocity Control Mode

- Parameter SL2 sets the control mode to velocity control.

SL1: Torque control mode

SL2: Velocity control mode

SL3: Inhibit

Velocity control via the RS-232C command or the analog command may be selected in the velocity control mode.

Parameter AC selects the way of control.

AC0 : Analog command invalid. DC command is valid.

AC1 : Analog command valid. When analog velocity command is +: CW direction

AC-1 : Analog command valid. When analog velocity command is -: CCW direction

3.2.1. Velocity Control with RS-232C Command

- Motor velocity may be controlled directly through the RS-232C command in the velocity control mode.
- Parameter AC (AC0) sets validity of DC command.
Inputting

D **C** (data) **ENT**

will have the Motor controlled with the velocity that is proportional to the data.

- Relation between the data of DC command and the velocity is shown in Figure 3-2.

Figure 3-2: DC command VS the velocity

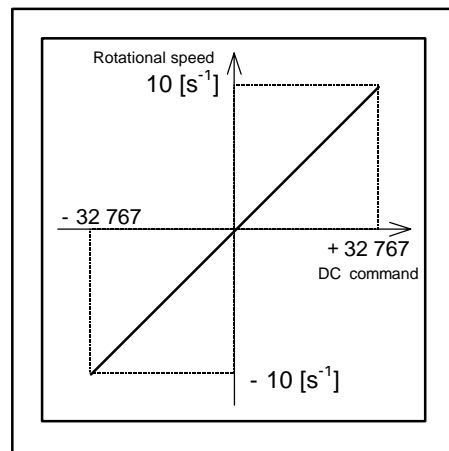

 **Caution** : AS DI parameter reverses the sign of coordinate, the polarity of the DC command is reversed as well. DI parameter is set to "0" in shipping.

: Please confirm the speed of the motor.

3.2.2. Velocity Control with Analog Command

- Velocity of the Motor may be directly controlled with the analog velocity command in the velocity control mode.
- Voltage range of the analog command is $\pm 10[V]$. Offset adjustment is possible setting parameter AF. (Refer to “3.2.2.1. Offsetting Analog Velocity Command.”)
- Parameter AC selects the polarity of command voltage. (Refer to Table 3-2.)
- Relation between the command voltage and the velocity may be selected with parameter AG. (See Figure 3-3.)

Table 3-2: Rotating direction relater to DI,AC and the polarity of Command voltage

DI setting	AC setting	Command voltage	Rotating direction
0	1	+	CW
0	1	-	CCW
0	-1	+	CCW
0	-1	-	CW
1	1	+	CCW
1	1	-	CW
1	-1	+	CW
1	-1	-	CCW

Figure 3-3: Command voltage and velocity (DI=0)

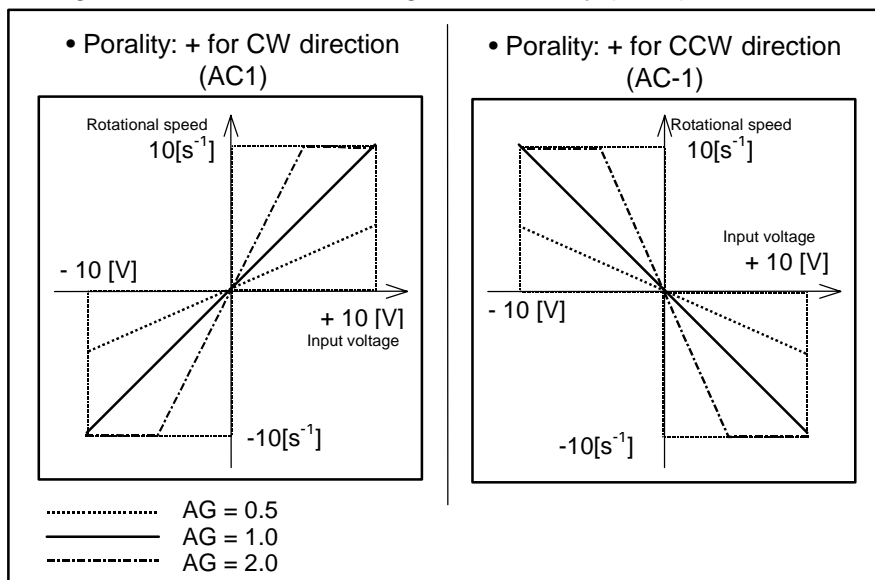

 **CAUTION** : Please confirm the speed of the motor.

: When using the motor which max speed is less than $10[s^{-1}]$ set the parameter AG not to exceed its max rotation speed.

3.2.2.1. Offsetting Analog Velocity Command

- You may adjust offset value of command voltage with the parameter AF.
- Parameter AF sets the offset value by “0.3[mV]” per parameter data in the range of AF-6552 to AF6552.

Figure 3-4: Example: Setting AF-10 (AC1)

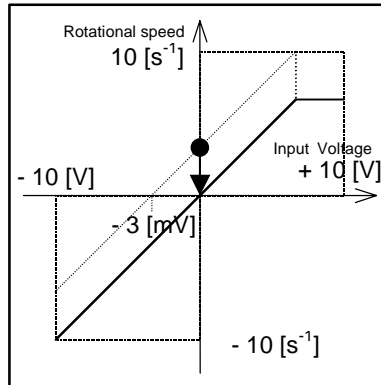

(1) Automatic offset setting

- Set the offset value automatically to compensate current analog input, which is caused by the drift, to 0 (zero).

- (1) Connect the master controller and the Driver Unit, and then input analog velocity command 0 (zero).
- (2) Input the password. The acknowledgement will be returned.

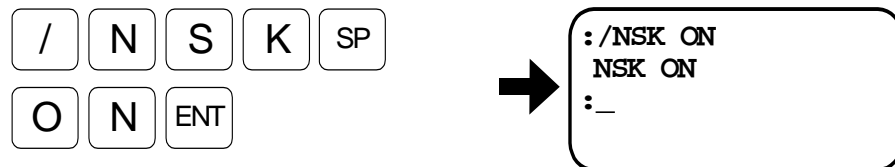

- (3) Input as

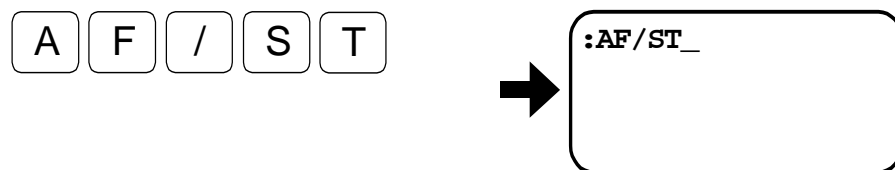

- (4) Pressing the **ENT** key sets the offset value automatically. The set value of AF will be on the screen.

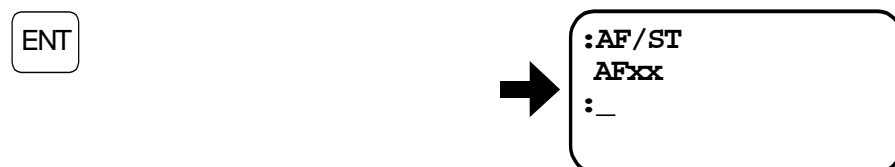

- Unit of setting value is 0.3[mV].
- If the offset value is too much, it indicates as “RANGE OVER?”. However, the offset value won't be changed.

(2) Manual offset setting

- Set offset value with the analog command monitor.

- (1) Take a memo of setting on polarity of the analog command AC, and then change those settings to AC1.
- (2) Connect the master controller and the Driver Unit and input the velocity command of 0 (zero).
- (3) Type as shown below and monitor the analog command.

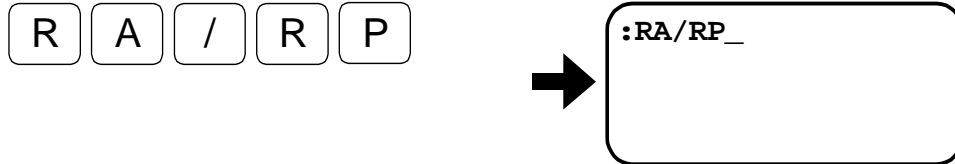

- (4) When the `ENT` key is pressed, the current analog command due to the drifting will be shown in the screen repeatedly. Indication of 2, as shown in the screen below, denotes that the offset to the command voltage shall be $0.6 \text{ mV} (0.3[\text{mV}] \times 2)$.



- (5) Confirm the result and press the `BS` key. Otherwise the next command won't be accepted.



- (6) Input the password. The acknowledgement will be returned.

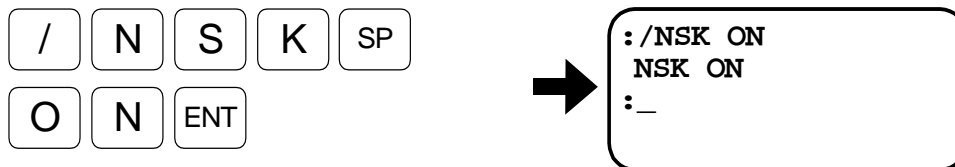

- (7) Execute the following commands. Be sure to input the opposite sign as it was monitored by the RA command.



- (8) Reset the analog command polarity AC to the setting as noted at the step (1).

3.3. Torque Control Mode

- Parameter SL1 selects the torque control mode.
SL1: Torque control mode
SL2: Velocity control mode
SL3: Inhibit
- Torque control via the RS-232C command or the analog command may be selected. Parameter AC selects the way of control.
AC0 : Analog command invalid. DC command is valid.
AC1 : Analog command valid. When analog torque command is +: CW rotation
AC-1 : Analog command valid. When analog torque command is -: CCW rotation

3.3.1. Torque Control with RS-232C Command

- You may control directly the motor output torque with RS-232C command in the torque control mode.
- Set the parameter AC (AC0) to make the DC command valid.

Input as

D **C** (data) **ENT**

to control the motor with torque proportional to the parameter data.

- Relation between the data of DC command and the motor output torque is shown in Figure 3-5.

Figure 3-5: DC command VS the motor output torque

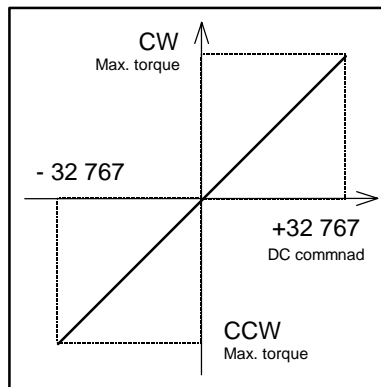

3.3.2. Torque Control with Analog Command

- You may control directly the output torque of the Motor with analog torque command in the torque control mode.
 - ✧ Voltage of analog torque command is $\pm 10[V]$. Offsetting analog command is possible setting parameter AF. (Refer to “3.3.2.1. Offsetting Analog Torque Command.”)
 - ✧ Parameter AC selects the polarity of command voltage. (See Table 3-3.)
 - ✧ Relation between the command voltage and the output torque of the Motor may be changed with parameter AG. (Refer to Figure 3-6.)

Table 3-3: Rotating direction relater to DI,AC and the polarity of Command voltage

DI setting	AC setting	Command voltage	Rotational direction
0	1	+	CW
0	1	-	CCW
0	-1	+	CCW
0	-1	-	CW
1	1	+	CCW
1	1	-	CW
1	-1	+	CW
1	-1	-	CCW

Figure 3-6: Command voltage and output torque (DI=0)

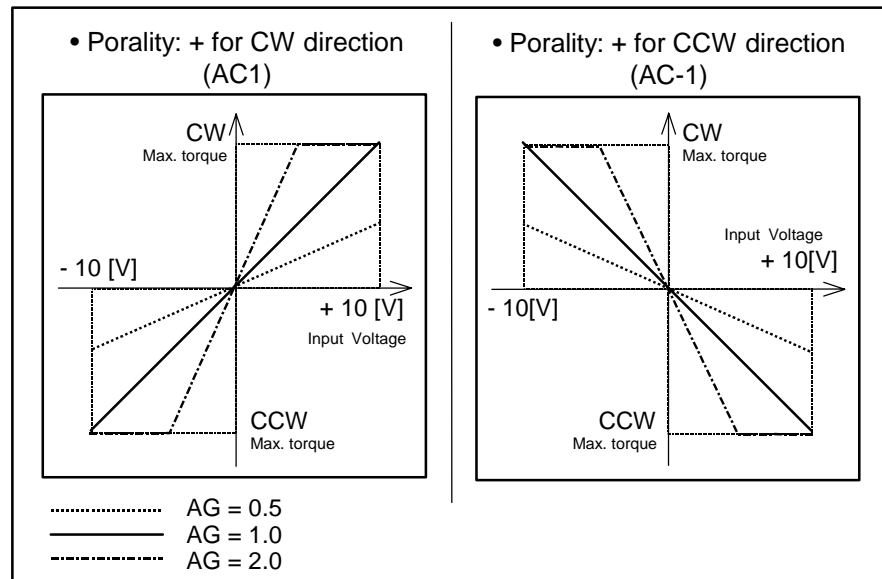

3.3.2.1. Offsetting Analog Torque Command

- You may adjust offset value of command voltage with the parameter AF.
- Offset adjustment of the Driver Unit has been made at the shipping. With the parameter AF, reset the offset along the master controller.
- Parameter AF sets the offset value by 0.3[mV] per parameter data in the range of AF –6552 to AF 6552.

Figure 3-7: Example: AF-10 (AC1)

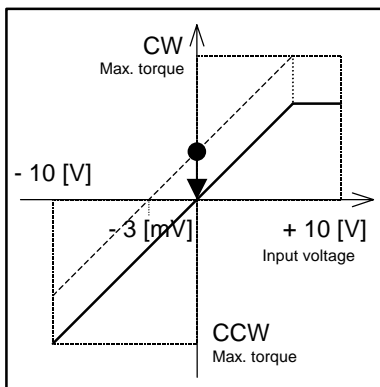

(1) Automatic offset setting

- Set the offset value automatically to compensate current analog input, which is caused by the drift, to 0 (zero).
- Refer to (1) Automatic offset setting in “3.2.2.1. Offsetting Analog Velocity Command.”

(2) Manual offset setting

- Adjust offsetting manually with the analog command monitor.
- Refer to (2) Manual offset setting in “3.2.2.1. Offsetting Analog Velocity Command.”

4. Glossary of Commands and Parameters

The password must be entered before inputting a command that is marked with ★.

★ **AC** : Analog Command Mode

Format : AC data
Data : -1, 0, 1
Shipping set : 1

- Sets the validity (valid/invalid) and sign of the analog command input.
AC0 : Analog command input invalid. DC command is valid.
AC1 : Analog command input valid. Voltage +: CW direction
AC-1 : Analog command input valid. Voltage +: CCW direction
- When the parameter DI is set to reverse the sign of position scale, above signs shall be reversed as well.
- TS0 or ?AC command reports the current setting.

★ **AF** : Analog Command Offset

Format1 : AF/ST Automatic setting
Format2 : AF data Manual setting
Data range : - 6552 to 6552
Shipping set : 0

- Sets the offset value on input voltage of analog command.
- For more details about the parameter AF, refer to “3.2.2.1. Offsetting Analog Velocity Command” in case of the analog velocity control mode, or “3.3.2.1. Offsetting Analog Torque Command” in case of the analog torque control mode.

TS0 or ?AF reports the current setting.

★ **AG** : Analog Command Gain

Format : AG data
Data range : 0.0001 to 2.0000
Shipping set : 1

- This parameter sets the analog command gain in the velocity or torque control mode.
- Actual gain value is proportional to the velocity or torque command.
 - Example
When AG0.5:
$$\text{Actual velocity command} = \text{Velocity command input} \times 0.5$$
- TS0 or ?AG command reports the current setting.

AFP : Analog Command Filter, Primary

Format	: AFP data	
Data range1	: 0	Primary analog command filter is OFF
Data range2	: 10 to 1000	[Hz]
Shipping set	: 200	

- This parameter sets the low-pass filter against the analog command.
- TS0 or ?AFP command reports the current setting.

AFS: Analog Command Filter, Secondary

Format	: AFS data	
Data range1	: 0	Secondary analog command filter is OFF
Data range2	: 10 to 1000	[Hz]
Shipping set	: 0	

- This parameter sets the low-pass filter against the analog command.
- TS0 or ?AFS command reports the current setting.

DC: Digital Command Mode

Format	: DC data
Data range	
Torque control mode	: - 32 767 to 32 767 (CW in positive command)
Velocity control mode	: - 32 767 to 32 767 (CW in positive command)
Shipping set	: 0

- This command is to input directly the operation command through the RS-232C communication interface in velocity or torque control mode.
However, the use of this command shall be limited to an ordinal operation, or a testing operation of the Motor due to sluggish response.
- If DC command is inputted when an analog command (AC command) is valid, “DC INHIBITED” message will be given and the command will be invalidated.
- The data of this command will be cleared to “0” in the following state.
 - 1) Servo off
 - 2) Emergency stop
 - 3) Over travel limit
 - 4) Control mode is switched.
 - 5) Analog command is valid.
 - 6) MS command is executed, or STP input is ON.

 **Caution** : When the sign of the position scale is reversed with DI command, the sign of DC command will be reversed as well.

RA: Read Analog Command

Format : RA/RP

- Reads an analog command value when the analog command is valid.
- “RA INHIBITED” message will be returned when the analog command is invalid.
- Adding /RP to RA command will report the reading repeatedly, while RA input alone reports in one shot. To quit from the repetitive readings, press the **BS** key.
- The report is a decimal number in $-32\,767$ to $32\,767$.

★ SL:Set Control Mode

Format : SL data

Data : 1, 2

Shipping set : 2

- Sets the control mode.
 - SL1 : Torque control mode
 - SL2 : Velocity control mode

TS0 or ?SL command reports the current setting.

(Blank page)

5. Conformity with the International Safety Regulations

The Megatorque Motor Systems conform to the EU Directives (CE Marking) and Underwriters Laboratory (UL) regulations.

5.1. Conformity with the EU Directives

The Megatorque Motor System is a machine component that conforms to provisions of the EU Low Voltage Directive. This will help a user in easy conformity with the EU Directives (CE marking) of a machine into which the Megatorque Motor System is incorporated.

5.2. Conformity with Electromagnetic Compatibility Directive

- The Motor and the Driver Unit of a model of the Megatorque Motor System, which has a four-meter long connecting cable, were tested under the specific conditions, such as their installing distance and wiring routing. The model has been confirmed for its conformity with the related regulations of the EMC Directive. However, your actual use conditions for wiring and installations won't be the same as our tested model. Thus, you have to check your machine, especially on the radiated noise and conducted noise, for the conformity with the EMC Directive as a complete machine after installation of the Megatorque Motor System.

Table 5-1: List of relevant standards

Item	Conformed regulation	
Megatorque Motor	EN60034-1	Low Voltage Directive
	EN61800-5-1	
Motor / Driver Unit	EN55011 : Group1, Class A Conducted noise	Electromagnetic Compatibility Directive
	EN55011 : Group1, Class A: Radiated noise	
	EN61000-6-2 : Immunity standard for industrial environments	
	EN61000-4-2 : Electro static discharge	
	EN61000-4-3 : Radio-frequency electromagnetic field	
	EN61000-4-4 : Electric fast transit burst	
	EN61000-4-5 : Lightning surges	
	EN61000-4-6 : Radio frequency conducted disturbance	
	EN61000-4-8 : Power frequency magnetic field	
	EN61000-4-11 : Voltage dips and short interruption	

Caution *This equipment is not intended for use in residential environments and may not provide adequate protection to radio reception in such environments.*

Warning *In a residential environment, this product may cause radio interference, in which case supplementary appropriate mitigation measures may be required.*

Conditions to Conform with EU Directives

The wiring example shown below is one of our recommendations for the conformity with the EU Directives.

Figure 5-1: Wiring diagram (Example)

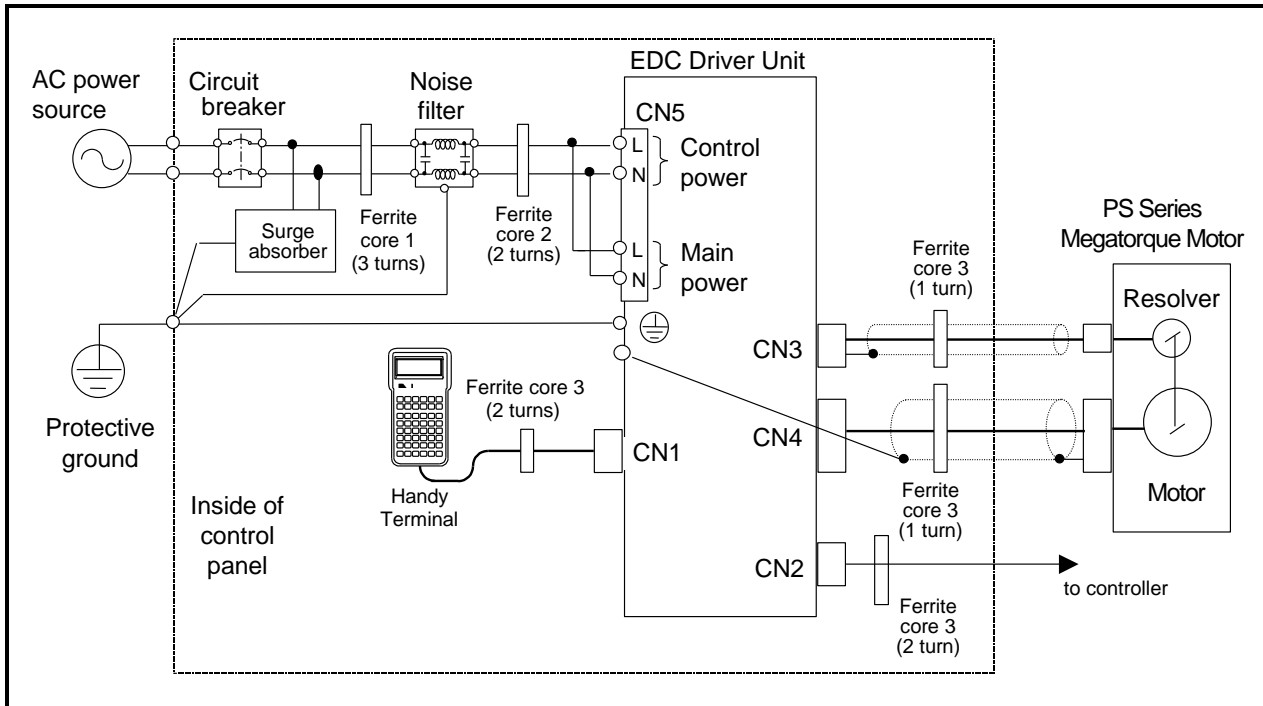

◆ Environmental conditions

The Driver Unit must be used in the environmental condition of Pollution Degree1 or 2 as specified by IEC60664-1. The Driver Unit shall be installed into a control panel with the structure that does not allow penetration of water, oil or dust (IP54).

◆ Power source

The EDC Driver Unit shall be used in the environmental condition of “Over-voltage category III” as specified by IEC60664-1.

◆ Circuit breaker

Install a circuit breaker that conforms to IEC standard and UL safety standard between the power source and the Driver Unit.

◆ Noise filter

Install a noise filter between the power source and the Driver Unit.

◆ Ferrite core

Ferrite cores for signal cable shall be set to the power cable, the Motor cable and the resolver cable.

◆ Protective Grounding

Be sure to ground the protective grounding terminal of the EDC Driver Unit to the protective ground (PE) of the control panel for a measure against electrical shock.

Table 5-2: List of recommended part

Item	Specification	Manufacturer	Remarks
Circuit breaker	Rated current: 15[A]	BW32AAG (Fuji Electric)	Conforms to IEC regulations and approved by UL
Noise filter	Single phase: 250[VAC], 10[A]	FN2070-10/06 (SHAFFNER)	
Surge absorber	—	R-A-V781BWZ-4 (Okaya electric)	
Ferrite core 1	—	E04RA400270150 (Seiwa Electric MFG)	
Ferrite core 2	—	E04SR301334 (Seiwa Electric MFG)	For the Handy Terminal
Ferrite core 3	—	E04SR21132 (Seiwa Electric MFG)	

The following are the conditions for meeting EN60364-4-41.

Table 5-3: Maximum allowable fault loop impedance value in the system (for TN system)

Supply voltage	Circuit breaker			Maximum allowable fault loop impedance
	Specification	Manufacture Model	Manufacturer	
100~115 [VAC]	Rated Current: 15[A]	BW32AAG	Fuji Electric	0.5 [Ω]
200~230 [VAC]				1.0 [Ω]

Table 5-4: Maximum allowable fault loop impedance value in the system (for TT system)

Supply voltage	Earth leakage circuit breaker			Maximum allowable fault loop impedance
	Specification	Manufacture Model	Manufacturer	
100~115 [VAC]	Rated Current: 30[A]	ZL63-30-30	Kawamura Electric	200 [Ω]
200~230 [VAC]	Rated sensitivity current: 30[mA]			450 [Ω]

- The rated sensitivity current and the maximum allowable fault loop impedance may be specified depending on the installation environment.
- An earth leakage breaker (Type B) sensing direct current may be required.

◆ Others

The motor over temperature protection of the Driver Unit doesn't link to speed.
It doesn't have the function that store and retain the estimated value of heat generation.

5.3. Conformity with Underwriters Laboratories Standards

The Megatorque Motor and the EDC Driver Unit are qualified products for the following UL Standard for safety.

Table 5-5

Subject	Qualified regulation	File No.
Megatorque Motor	UL1004	E216970
Driver Unit	UL508C	E216221

Conditions to Meet UL Standards

Be sure to meet the following as they are the supplementary conditions for the qualification.

◆ **Environmental conditions**

The Driver Unit must be used in the environmental condition of Pollution Degree1 or 2 as specified by IEC60664-1. The Driver Unit shall be installed into a control panel with the structure that does not allow penetration of water, oil or dust (IP54).

◆ **Power source**

The EDC Driver Unit shall be used in environmental condition of “Over-voltage category III” as specified by IEC60664-1.

◆ **Circuit breaker**

Install a circuit breaker that conforms the UL safety standard between the power source and the Driver Unit. (Please refer to Table 2 above for the specifications.)

◆ **Protective Grounding**

Be sure to ground the protective grounding terminal of the EDC Driver Unit to the protective ground (PE) of the control panel for a measure against electrical shock.

MEGATORQUE™ MOTOR SYSTEM

User's Manual

(EDC Driver Unit System)

Analog Driver Unit with Analog Interface

Document Number: C20171-05

Jun 12, 2008	1st Edition
July 16, 2008	2nd Edition
Jan 17, 2013	3rd Edition
Dec 21, 2021	4th Edition
Mar 16, 2022	5th Edition

NSK Ltd.

Worldwide Sales Offices

P: Phone ☆: Head Office

NSK LTD. HEADQUARTERS, TOKYO JAPAN

INDUSTRIAL MACHINERY BUSINESS DIVISION-HEADQUARTERS P: +81-3-3779-7227
 AUTOMOTIVE BUSINESS DIVISION-HEADQUARTERS P: +81-3-3779-7189

Africa

South Africa:

NSK SOUTH AFRICA (PTY) LTD.
 SANDTON P: +27-011-458-3600

Asia and Oceania

Australia:

NSK AUSTRALIA PTY. LTD.
 MELBOURNE ☆ P: +61-3-9765-4400
 SYDNEY P: +61-2-9839-2300
 BRISBANE P: +61-7-3347-2600
 PERTH P: +61-8-9256-5000

New Zealand:

NSK NEW ZEALAND LTD.
 AUCKLAND P: +64-9-276-4992

China:

NSK (SHANGHAI) TRADING CO., LTD.
 JIANGSU ☆ P: +86-512-5796-3000

NSK (CHINA) INVESTMENT CO., LTD.

JIANGSU ☆ P: +86-512-5796-3000
 BEIJING P: +86-10-6590-8161
 TIAN JIN P: +86-22-8319-5030
 CHANGCHUN P: +86-431-8898-8682
 SHENYANG P: +86-24-2334-2868
 DALIAN P: +86-411-8800-8168
 NANJING P: +86-25-8472-6671
 FUZHOU P: +86-591-8380-1030
 WUHAN P: +86-27-8556-9630
 QINGDAO P: +86-532-5568-3877
 GUANGZHOU P: +86-20-3817-7800
 CHANGSHA P: +86-731-8571-3100
 LUOYANG P: +86-379-6069-6188
 XI'AN P: +86-29-8765-1896
 CHONGQING P: +86-23-6806-5310
 CHENGDU P: +86-28-8528-3680

NSK CHINA SALES CO., LTD.

JIANGSU ☆ P: +86-512-5796-3000

NSK HONG KONG LTD.

HONG KONG ☆ P: +852-2739-9933
 SHENZHEN P: +86-755-25904886

Taiwan:

TAIWAN NSK PRECISION CO., LTD.

TAIPEI ☆ P: +886-2-2772-3355
 TAICHUNG P: +886-4-2708-3393
 TAINAN P: +886-6-215-6058

India:

NSK BEARINGS INDIA PRIVATE LTD.

CHENNAI ☆ P: +91-44-2847-9600
 MUMBAI P: +91-22-2838-7787
 JAMSHEDPUR P: +91-657-2421144
 GURGAON P: +91-124-4838000

Indonesia:

PT. NSK INDONESIA
 JAKARTA P: +62-21-252-3458

Korea:

NSK KOREA CO., LTD.
 SEOUL P: +82-2-3287-0300

Malaysia:

NSK BEARINGS (MALAYSIA) SDN.BHD.
 SHAH ALAM ☆ P: +60-3-7803-8859
 PRAI P: +60-4-3902275
 JOHOR BAHRU P: +60-7-3546290
 IPOH P: +60-5-2555000

Philippines:

NSK REPRESENTATIVE OFFICE
 MANILA P: +63-2-893-9543

Singapore:

NSK INTERNATIONAL (SINGAPORE) PTE LTD.
 SINGAPORE P: +65-6496-8000

NSK SINGAPORE (PRIVATE) LTD.
 SINGAPORE P: +65-6496-8000

Thailand:

NSK BEARINGS (THAILAND) CO., LTD.
 BANGKOK P: +66-2320-2555

Vietnam:

NSK VIETNAM CO., LTD.
 HANOI P: +84-24-3955-0159

NSK REPRESENTATIVE OFFICE
 HO CHI MINH CITY P: +84-28-3822-7907

Europe

United Kingdom:

NSK EUROPE LTD. (EUROPEAN HEADQUARTERS)
 MAIDENHEAD P: +44-1628-509-800

NSK UK LTD.
 NEWARK P: +44-1636-605-123

France:

NSK FRANCE S.A.S.
 PARIS P: +33-1-30-57-39-39

Germany:

NSK DEUTSCHLAND GMBH
 DUSSELDORF ☆ P: +49-2102-4810
 STUTTGART P: +49-711-79082-0
 WOLFSBURG P: +49-5361-27647-10

Italy:

NSK ITALIA S.P.A.
 MILANO P: +39-299-5191

Netherlands:

NSK EUROPEAN DISTRIBUTION CENTRE B.V.
 TILBURG P: +31-13-4647647

Poland:

NSK REPRESENTATIVE OFFICE
 WARSAW P: +48-22-645-1525

Russia:

NSK POLSKA SP. Z O.O.
 SAINT-PETERSBURG P: +7-812-332-5071

Spain:

NSK SPAIN S.A.
 BARCELONA P: +34-93-289-2763

Turkey:

NSK RULMANLARI ORTA DOGU TIC. LTD. STI.
 ISTANBUL P: +90-216-5000-675

United Arab Emirates:

NSK BEARINGS GULF TRADING CO.
 DUBAI P: +971-(0)4-804-8200

North and South America

United States of America:

NSK AMERICAS, INC. (AMERICAN HEADQUARTERS)
 ANN ARBOR P: +1-734-913-7500

NSK CORPORATION

ANN ARBOR P: +1-734-913-7500

NSK PRECISION AMERICA, INC.

FRANKLIN ☆ P: +1-317-738-5000
 SAN JOSE P: +1-408-944-9400

NSK LATIN AMERICA, INC.

MIAMI P: +1-305-477-0605

Canada:

NSK CANADA INC.

TORONTO ☆ P: +1-888-603-7667
 MONTREAL P: +1-514-633-1220

Argentina:

NSK ARGENTINA SRL
 BUENOS AIRES P: +54-11-4704-5100

Brazil:

NSK BRASIL LTDA.

SUZANO ☆ P: +55-11-4744-2500
 JOINVILLE P: +55-47-3422-2239

Peru:

NSK PERU S.A.C.

LIMA P: +51-493-4385

Mexico:

NSK RODAMIENTOS MEXICANA, S.A. DE C.V.

SILAO, GUANAJUATO P: +52-472-500-9500

<As of August 2021>

For the latest information, please refer to the NSK website.

www.nsk.com

Every care has been taken to ensure the accuracy of data in this publication, but NSK Ltd. accepts no liability for any loss or damage incurred from errors or omissions. As we pursue continuous improvement, all content (text, images, product appearances, specifications, etc.) contained in this publication is subject to change without notice. Unauthorized copying and/or use of the contents of this publication is strictly prohibited.

Please investigate and follow the latest product export laws, regulations, and permit procedures when exporting to other countries.

For more information about NSK products, please contact: _____